

Chapter 1

Introduction to Ultrawideband Systems

Cong Ling

Imperial College London

In this chapter, we introduce the basics of ultrawideband (UWB) systems, the spectrum and regulations, and the advantages of UWB over conventional narrowband systems. We outline different schemes to realise UWB: impulse radio/time hopping, direct sequence, frequency hopping and orthogonal frequency division multiplexing (OFDM). Then we show the industrial standards and applications of UWB.

1.1. Overview

UWB refers to systems with very large bandwidth (Ghavami *et al.*, 2008; Aiello and Batra, 2006; Arslan *et al.*, 2006). This very large bandwidth offers several advantages including low power consumption, high data rate, high time resolution, low-cost implementation, obstacle penetration, resistance to interference, covert transmission, co-existence with narrowband systems and so on. Such advantages enable a wide range of applications of UWB to communications, radar, imaging and positioning.

Arguably, the first experiment on UWB was conducted by Hertz in 1893 (Ghavami *et al.*, 2008). In other words, the first wireless communication system was based on UWB. Hertz used spark gaps and arc discharges between carbon electrodes to generate electromagnetic waves. The usage of such wideband pulse waveforms was the dominant technique for many years after Hertz's first electromagnetic experiment. However, as technology progressed, the emphasis of communications shifted to narrowband sinusoidal waveforms. It was not until the 1990s that investigations into impulse radio sparked new interest in UWB. The technology of impulse radio was made possible by the corresponding techniques for generating short pulses developed in the 1960s.

Perhaps the greatest advantage of UWB is most evident from the famous Shannon formula for the capacity of a band-limited channel in Gaussian noise (Ghavami *et al.*, 2008):

$$C = W \log \left(1 + \frac{P}{WN_0} \right), \quad (1.1)$$

where C is the channel capacity in bits/second (bps), W is the channel bandwidth in Hz, P is the signal power in Watts and N_0 is the noise power spectral density in Watts/Hz. The Shannon formula shows that, given the noise power spectral density N_0 of the channel, the signal power P can be traded off with the bandwidth W while maintaining the same channel capacity C . In particular, we can decrease P if more bandwidth is available. On the other hand, given P the capacity C will increase with W . From an information-theoretic perspective, this trade-off between power and bandwidth motivated the development of wideband communication systems such as spread spectrum and UWB. The trade-off between power and bandwidth was known even in analog communication. Frequency modulation (FM) uses more bandwidth in return for higher signal quality than amplitude modulation (AM).

In spread-spectrum communication, the signal power is spread over a much wider bandwidth than the original (Simon *et al.*, 1994). However, the bandwidth of traditional spread-spectrum communication (on the order of MHz) is not comparable with that of UWB, which is on the order of GHz. This definition of UWB is not unique. Federal Communications Commission (FCC) in United States of America (USA) defines UWB as systems with bandwidth larger than 500 MHz or relative bandwidth W/f_c (f_c is the carrier frequency) larger than 20% (Aiello and Batra, 2006). Figure 1.1 shows the spectral mask of UWB defined by the FCC Part-15 rule and that of indoor UWB (FCC, 2002). Similar rules have been approved in other countries of the world. In particular, a very wide bandwidth of 7.5 GHz between 3.1 GHz and 10.6 GHz is available for UWB at the power emission level -41.3 dBm/MHz. In Fig. 1.1, the stricter limitation of power emission in the frequency band between 0.96 GHz and 1.61 GHz is due to existing services such as mobile communications, positioning systems and military usage.

Because of the low power spectral density of UWB, its interference can often be ignored by many existing systems occupying the same frequency bands. This property enables the unlicensed operation of UWB devices. Moreover, the short pulses of UWB lead to multipath immunity, i.e., the propagation paths can be identified due to its fine time resolution. This is because the resolution of the UWB receiver is approximately $1/W$; the larger W is, the higher is the resolution (Ghavami *et al.*, 2008). The fine time resolution is very useful for ranging and positioning. The short pulses also enable the penetration through walls and ground.

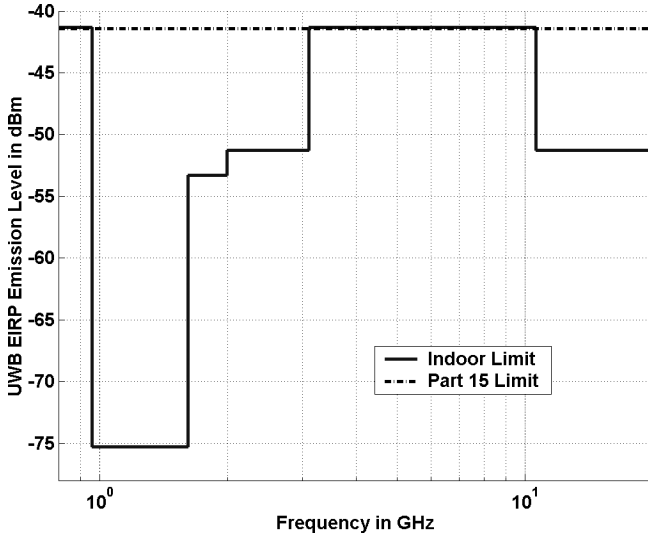

Fig. 1.1. Spectral mask defined by FCC for UWB. (FCC, 2002.)

Moreover, pulse-based UWB does not require carrier modulation, thus reducing the size and cost of UWB devices compared to conventional narrowband systems.

1.2. UWB Schemes

Despite being seen as a breakthrough technology, UWB is closely related to existing spread-spectrum communication. In particular, impulse radio, one of the UWB schemes, is also known as time-hopping (TH) in spread-spectrum communication. Other schemes to realise UWB include direct-sequence, frequency hopping and OFDM. Quite naturally, UWB offers the same possibility of code-division multiple access (CDMA) as conventional spread spectrum does, by assigning different signature codes to different users. Here, we present an outline of different UWB schemes. The details of UWB transceiver design and signal processing can be found in Yang and Giannakis (2004) and Qiu *et al.* (2005).

1.2.1. Impulse radio/time hopping

Impulse radio was the first proposed UWB scheme (Win and Scholtz, 1998; Win *et al.*, 2009) and has received most of the attention in the research community. Another name for impulse radio is time-hopping. Time-hopping is not a new technology; it has been used in spread-spectrum systems for many decades. Figure 1.2 shows the principle of impulse radio, where each data

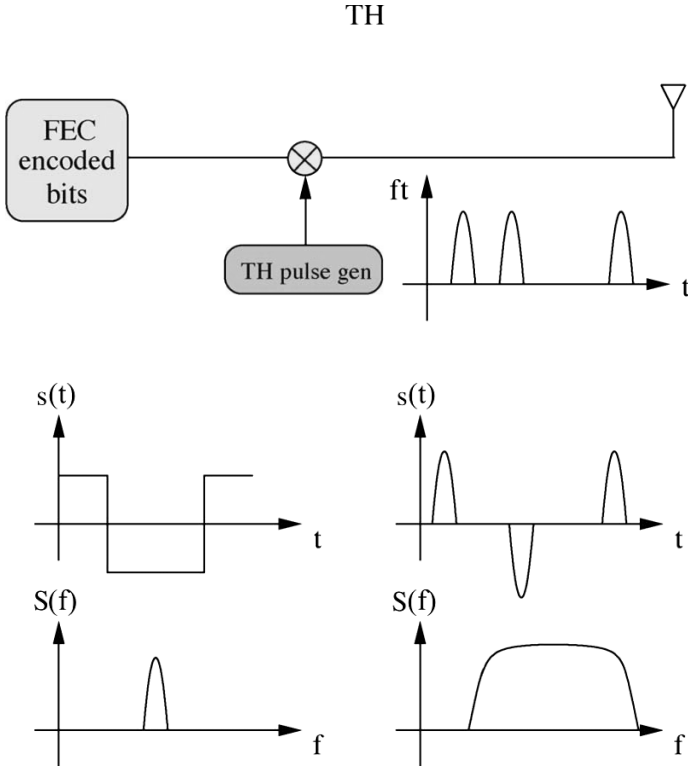

Fig. 1.2. Block diagram of TH impulse radio. $s(t)$: time-domain signal; $S(f)$: frequency-domain signal (Win *et al.*, 2009). (©2009 IEEE.)

symbol is associated to a sequence of very short duration pulses, typically of a sub-nanosecond, hence the name of impulse radio. The short pulses have their relative positions hopping in time according to a user-specific sequence. Due to the very short pulse duration, the spectrum is spread very thin from near DC to several GHz. In principle, the generation of this carrier-less signal allows for low complexity and low power-consumption transmitter implementation.

The signal emitted from the k th user in impulse radio consists of a large number of sub-nanosecond pulses (Win and Scholtz, 1998)

$$s^{(k)}(t) = \sum_{j=-\infty}^{\infty} w\left(t - jT_f - c_j^{(k)}T_c - \delta d_{\lfloor j/N_s \rfloor}^{(k)}\right), \quad (1.2)$$

where $w(t)$ is referred to as the monocycle (pulse shape), T_f is the pulse repetition period, $\{c_j^{(k)}\}$ is the time-hopping sequence associated with user k , $c_j^{(k)}T_c$

corresponds the time shift to the j th pulse. T_c is the duration of addressable time delay bins. The data sequence $\{d_j^{(k)}\}$ changes the delay via the modulation index δ , which should be chosen to optimise the performance. N_s monocycles are modulated by a data symbol, hence the data rate $R_s = 1/N_s T_f$. When there is more than one user, the time-hopping sequences should be carefully designed to minimise the collisions. In principle, time-hopping sequences can be adapted from frequency-hopping sequences (Simon *et al.*, 1994).

A typical pulse shape for the monocycle is the Gaussian doublet, given by Ghavami *et al.* (2006)

$$w(t) = \left[1 - 4\pi \left(\frac{t}{\tau_m} \right)^2 \right] e^{-2\pi \frac{t^2}{\tau_m^2}}, \quad (1.3)$$

where τ_m is the parameter to determine the frequency characteristic of the Gaussian doublet. This pulse shape can be easily generated by using simple circuits and antennas. Figure 1.3 shows the waveform of the Gaussian doublet and its frequency characteristic.

1.2.2. Direct sequence

UWB signals can also be generated by multiplying the original data sequence with a high-rate pseudo-random sequence. The conventional technique is called direct-sequence spread spectrum. The bandwidth of the resultant direct-sequence spread-spectrum signal will be expanded by a factor as large as the period of the pseudo-random sequence. This factor is also known as the processing gain (Simon *et al.*, 1994). Obviously, to create a UWB signal, the rate of the pseudo-random sequence needs to be much much higher than the original data rate. Figure 1.4 shows the diagram of direct-sequence spread spectrum. The properties of direct-sequence spread spectrum include low probability of interception/detection, robustness to interference and multipath propagation, and CDMA.

The design of pseudo-random sequences (spreading codes) for direct-sequence spread spectrum is well documented in literature. Good spreading codes should have low auto-correlation side lobes to ensure a flat spectrum of the signal. In CDMA applications, the spreading codes should also have low cross-correlation to reduce the inter-user interference. Some classical spreading sequences are the m sequence, Gold sequence, Kasami sequence, Bent sequence, GMW sequence and the No sequence (Simon *et al.*, 1994). Other spreading sequences including chaotic sequences that offer a trade-off between auto-correlation and cross-correlation (Oppermann and Vucetic, 1997; Ling and Li, 2001).

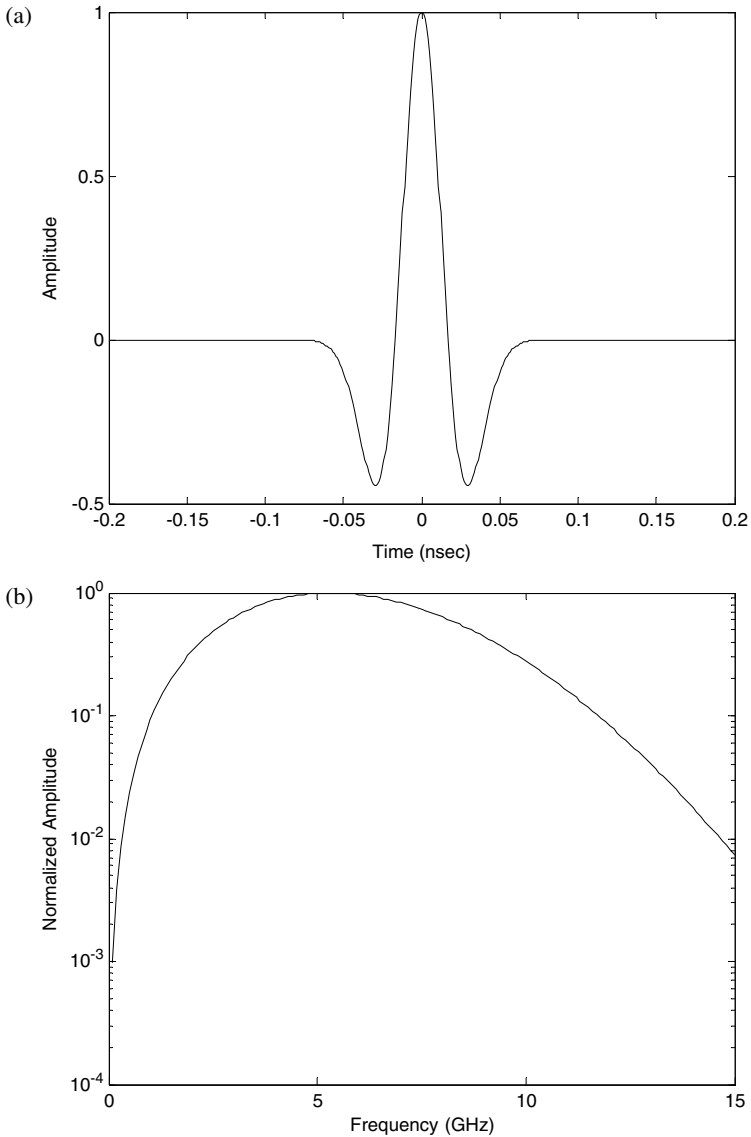

Fig. 1.3. (a) Pulse shape for impulse radio and (b) the corresponding frequency characteristics. $\tau_m = 0.06$ ns.

1.2.3. Frequency hopping

Frequency hopping is another classical approach to spread spectrum. Figure 1.5 illustrates the principle of frequency hopping, where the carrier frequency is

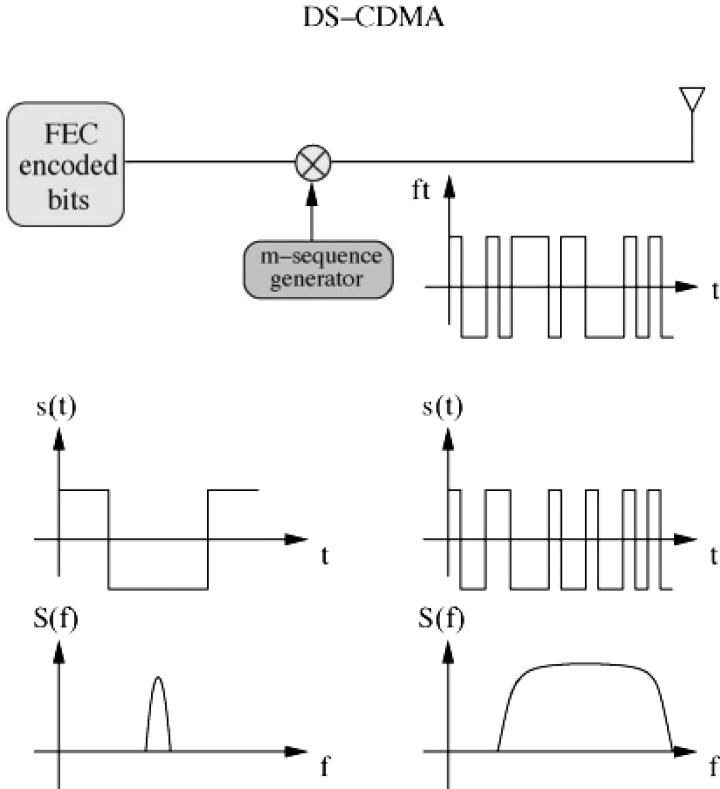

Fig. 1.4. Block diagram of direct-sequence spread spectrum. $s(t)$: time-domain signal; $S(f)$: frequency-domain signal (Win *et al.*, 2009). (©2009 IEEE.)

controlled by the frequency-hopping sequence (pattern) and hops over a certain frequency band. In a particular time constant, though, the frequency-hopping signal is a narrowband signal. The bandwidth of the frequency-hopping signal is determined by the bandwidth available, not by the rate of the frequency-hopping sequence.

Frequency hopping also has the advantages of low probability of interception, robustness to jamming and interference, and the capability of CDMA. Obviously, to maintain these properties over an ultrawide bandwidth, the carrier frequency needs to hop fast enough. Compared to the direct sequence technique, frequency hopping has another distinctive advantage in that the frequency slots do not have to be in one continuous frequency band. Therefore, in addition to spectrum flexibility, an adaptive frequency hopping system can skip those contaminated/jammed frequency slots.

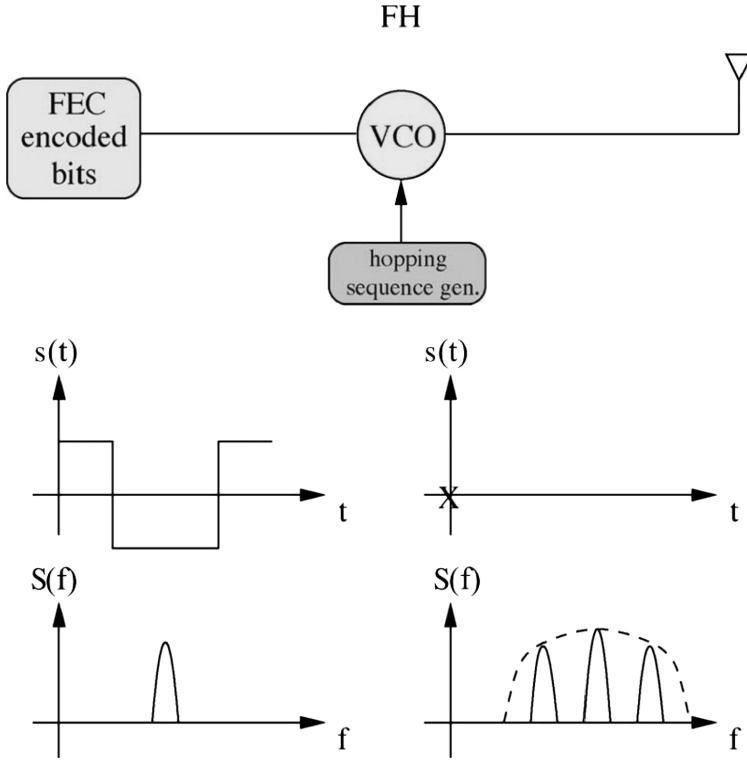

Fig. 1.5. Block diagram of frequency hopping. $s(t)$: time-domain signal; $S(f)$: frequency-domain signal (Win *et al.*, 2009). (© 2009 IEEE.)

Techniques for the design of frequency-hopping sequences are also well known (Simon *et al.*, 1994). Here, the design criterion is the Hamming correlation, which counts the number of hits in one period of the frequency-hopping sequence. In particular, the frequency-hopping sequences should have low Hamming autocorrelation to facilitate synchronization, while in CDMA applications, they should also have low Hamming cross-correlation to reduce the number of hits between different users. In the presence of an intelligent follow-on jammer, the frequency-hopping sequences should further have long period and strong nonlinearity. Short-period or linear sequences can be easily analysed and regenerated, which likely enable the follow-on jammer to completely undermine the processing gain. For such applications, highly nonlinear frequency-hopping sequences based on the chaos approach are well-suited (Ling and Sun, 1998; Ling and Wu, 2001).

1.2.4. OFDM

Alternatively, an ultrawide bandwidth can be created by multi-carrier modulation with a large number of carriers. In multi-carrier modulation, the original data sequence is split into many low-rate data streams, each of them modulating different parallel carriers (subcarriers). Let $S = [S_0, S_1, \dots, S_{N-1}]$ be a block of data symbols. The complex baseband representation of a multicarrier signal with N subcarriers is given by Han and Lee (2005).

$$s(t) = \frac{1}{\sqrt{N}} \sum_{n=0}^{N-1} S_n \cdot e^{j2\pi n \Delta f t}, \quad 0 \leq t \leq NT, \quad (1.4)$$

where Δf is the subcarrier spacing and NT is the data block period. In OFDM, the spacing between the subcarriers is properly chosen so that signals at different subcarriers are orthogonal to each other, i.e., $\Delta f = 1/NT$. Then, at discrete time instances $t = kT/N$, one has

$$s_k = \frac{1}{\sqrt{N}} \sum_{n=0}^{N-1} S_n \cdot e^{j2\pi nk/N}, \quad 0 \leq k \leq N-1, \quad (1.5)$$

which is precisely the inverse fast Fourier transform (IFFT) of the data block. Thus, OFDM can be conveniently implemented by the IFFT; the subcarriers need not be generated physically. This significantly reduces the implementation complexity and cost.

Figure 1.6 shows the block diagram of the full digital implementation of OFDM. The data symbols undergo the serial/parallel conversion, IFFT, and parallel/serial conversion before being sent into the channel. At the receiver, the inverse operations are applied, and the data are demodulated using FFT.

Figure 1.7 shows the various subcarrier spectra overlapping with one another. Note that each subcarrier spectral peak is at the nulls of other subcarrier spectra. Figure 1.8 shows the overall OFDM spectrum by adding all subcarrier spectra together. Obviously, one can make the bandwidth very large by using a large number of subcarriers, leading to the OFDM scheme of UWB.

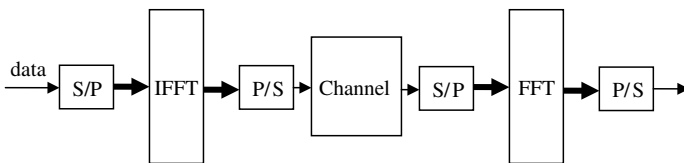

Fig. 1.6. Digital implementation of OFDM.

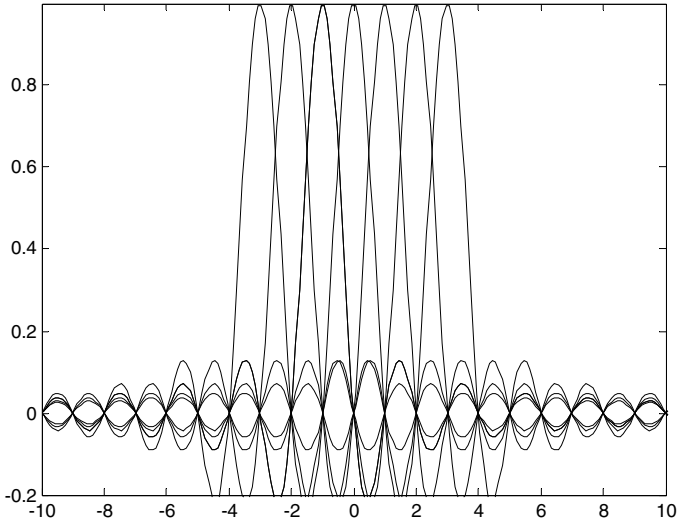

Fig. 1.7. OFDM spectral overlap.

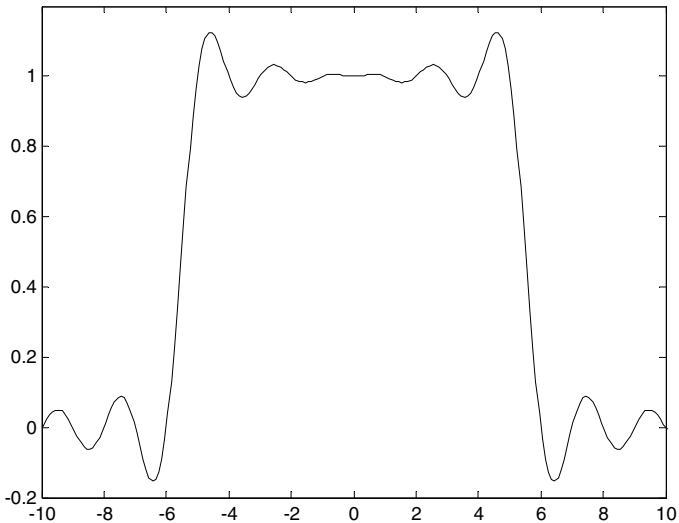

Fig. 1.8. OFDM spectrum.

An issue with OFDM is the high peak-to-average power ratio (PAPR). As the OFDM signal is a linear combination of some random data symbols, the amplitude can vary in a large range. The central limit theorem implies that the amplitude can be well approximated by the Rayleigh distribution for a large number of subcarriers.

Han and Lee (2005) provides an overview of PAPR reduction techniques such as clipping, filtering, coding, interleaving, partial transmit sequence and selected mapping.

Another issue is the inter-carrier interference (ICI). Although the subcarriers are orthogonal to each other in principle, the Doppler shift of the wireless fading channel may cause OFDM to lose orthogonality.

1.3. Industry Standards

1.3.1. Single band versus multiband

Initially, UWB was envisaged for a single frequency band of several GHz. However, such a truly ultrawideband system may be hard to implement, as the design of circuits is challenging and may lead to increased cost and power consumption. Further, it is vulnerable to strong interference at sporadic frequencies.

The multiband approach (Qiu *et al.*, 2005) addresses such issues by dividing the entire UWB spectrum into several sub-bands with bandwidth approximately 500 MHz. The 500 MHz bandwidth is to satisfy the minimum instantaneous bandwidth of an UWB signal as specified by FCC. Figure 1.9 shows the multiband spectrum allocation. Obviously, any of the UWB schemes can be used within a sub-band. The multiband approach offers flexibility in allocating spectrum and dealing with interference since the spectrum does not need to be contiguous. In addition, it is easier to implement any UWB scheme over a sub-band than that over the entire bandwidth.

1.3.2. Standards

Within the IEEE 802.15 working group, there are several standards for wireless personal area networks. The IEEE 802.15.3 standard is an evolution of the Bluetooth specification. UWB emerged as a strong candidate. Thus the IEEE 802.15.3SGa committee was formed to define the standard. Some companies promoted the direct-sequence UWB approach, while others supported multiband OFDM. However, neither approach could obtain the necessary 75% approval and

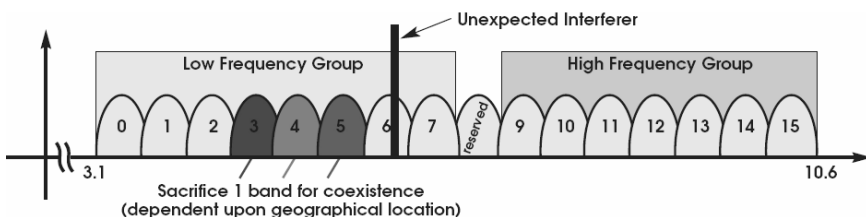

Fig. 1.9. Multiband spectrum allocation (Pendergrass, 2003). (©2009 IEEE.)

the standard definition process became a deadlock (Aiello and Batra, 2006). Finally, IEEE 802.15.3SGa was withdrawn. Nonetheless, both approaches of UWB survive in other standards.

The IEEE 802.15.4a standard, which addresses wireless personal area networks and wireless sensor networks, has adopted the impulse radio scheme (Zhang *et al.*, 2009). The mission of IEEE 802.15.4a is to develop a new physical layer for applications such as sensor networks. The 802.15.4a standard provides an enhanced communications capability to the 802.15.4-2006 standard and also provides device ranging to enable the geolocation capability. In addition to the 850 kb/s mandatory data rate, it provides variable data rates such as 110 kb/s, 1.70 Mb/s, 6.81 Mb/s, and 27.24 Mb/s. The UWB signal bandwidth is 500 MHz for the mandatory modes of IEEE 802.15.4a, with optional bandwidths of greater than 1 GHz.

The ECMA-368/9 (WiMedia Alliance) standard for short-range high-data rate wireless connectivity uses the multiband OFDM-based UWB technology (Kumar and Buehrer, 2008). It enables data rates up to 480 Mbps. It has been adopted by USB Implementers Forum as the Wireless USB standard and by the Bluetooth Special Interest Group as the next generation Bluetooth 3.0 standard for new consumer electronics. The eventual data rates of both standards will likely be even higher. Such speeds are substantially higher than Bluetooth 2.0 (which supports a maximum speed of 2 Mb/s) and wireless LAN IEEE 802.11g (which supports a maximum speed of 54 Mb/s.) The physical layer of WiMedia defines six band groups over the entire UWB frequency spectrum (3.1–10.7 GHz). Each band group consists of three 528 MHz-wide bands. A total of ten channels are defined in each band group, which are differentiated according to the frequency-hopping patterns.

1.4. Applications

We briefly mention the applications of UWB in communications. The applications of UWB will be further explained in Chap. 10.

Short-range high-speed communication appears to be the most popular application of UWB. The industrial standards mentioned in the preceding section reflect the huge industrial interest in this application. With such standards in place, companies have begun to produce large volumes of UWB chips and systems. Applications include computers, mobile phones, digital cameras, removable hard disks, set-top boxes and so on.

While short-range communications is the killer application of UWB, it is worth mentioning that UWB is also capable of long-range communications. This should come as no surprise since the UWB technology originated in short-pulse radar systems (Aiello and Batra, 2006). Meanwhile, time hopping is a classical approach

to spread spectrum, and has been used in military communications such as the Tracking and Data Relay Satellite System (TDRSS) for decades.

Another major application of UWB is ranging and localisation (Ghavami *et al.*, 2008). The precision of ranging depends on the bandwidth. The extremely large bandwidth of UWB means high precision of ranging. Specifically, the multi-gigahertz bandwidth of UWB leads to the ranging accuracy on the order of 1 cm. The potential of integrate ranging, location and communication makes UWB an attractive candidate for future systems.

A wireless sensor network is a network consisting of a large number of spatially distributed, cheap sensors used to monitor an environment. Wireless sensor networks have military, civil and industrial applications such as battlefield surveillance, environmental monitoring, healthcare, logistics and traffic control. The sensors usually have limited sizes, capability and battery life. Thus, UWB is a good choice of communication between the sensors because of its low-cost and low power consumption (Yang and Ginanakis, 2004). In addition, the precise localisation capability of UWB can improve positioning accuracy for wireless sensor networks. A good overview of UWB-based sensor networks can be found in Zhang *et al.* (2009).

1.5. Challenges

UWB also poses several challenges. Due to its extremely large bandwidth, the interference between UWB and narrowband systems is a major concern (Aiello and Batra, 2006). There are regulations of spectrum usage to avoid interference between different systems. The users of the spectrum have often paid a lot for it at auction, and therefore must be convinced that UWB will not cause undue interference to existing services. Moreover, all kinds of interference from existing narrowband services across the extremely large bandwidth of UWB may result in considerably stronger disturbances than background noise. This would mean that the equivalent noise power spectral density N_0 in Eq. (1.1) might be considerably larger, which may undermine the capacity promise of UWB.

The promise of low-cost implementation might also be undermined if simple circuits for signal reception and interference combating were unavailable.

Last but not least, the design of UWB antennas is considerably more challenging than conventional antennas. Conventional wideband antennas cannot transmit UWB signals without distortion. It is also more difficult to characterise UWB antennas, as traditional narrowband antenna parameters are not directly useful to UWB. The design of UWB antennas is even more challenging for small mobile terminals. These challenges will be addressed in the rest of this book.